

VULCAN CHAIN BLOCK



TWO YEAR WARRANTY

Superior quality

Approved ANSI B30.16

Overload protection available

Technical sheet

- 1/2T to 20T
- High quality heat treated alloy steel load chain
- Light weight for portability
- 2 load chain guides
- Weston type brake
- Very low headroom
- Hooks are forged heat treated steel
- Hand chain polished and 3 foot less than lift
- Safety orange finish with capacity markings



TECHNICAL SPECS

MODEL	Cap. Tons	Safe working load	Standard lift	Pulling effort	No. of chain falls	Net weight
		lb		lb		lb
VB1/2T	1/2	1 102	10	46.2	1	17.6
VB1T	1	2 204		52.8	1	23.1
VB1.5T	1,6	3 527		64.9	1	33
VB2T	2	4 409		73.7	1	46.2
VB3T	3.2	7 054		83.6	1	67.1
VB5T	5	11 023		79.2	3	77
VB10T	10	22 046		94.6	3	167.2
VB15T	15	33 069		103.4	5	341
VB20T	20	44 092		99	6	550

VULCAN CHAIN BLOCK



Dimensions

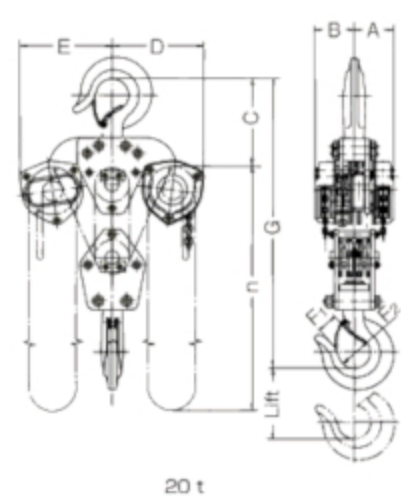
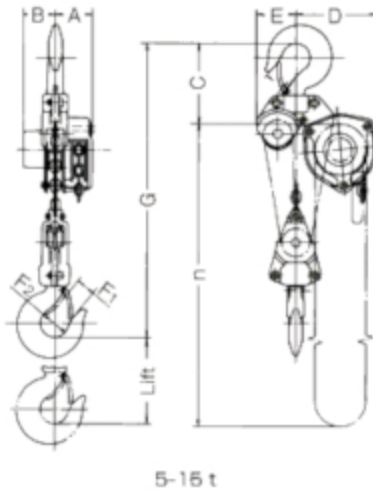
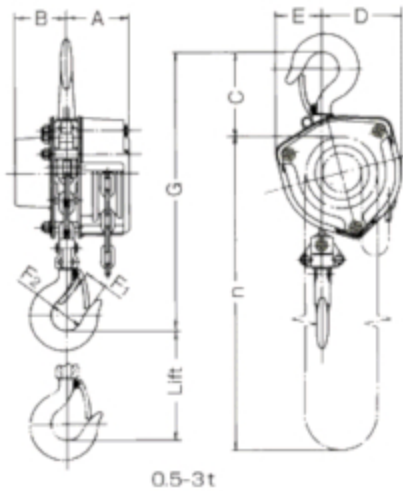

Cap. tons	Dimensions in						
	A	B	D	E	F1	F2	G Headroom
1/2	3 1/4	2 1/4	3 1/2	1 7/8	1 15/16	1 3/16	11 1/4
1	3 1/4	2 1/2	4	2 3/8	1 9/64	1 27/64	13 1/2
1.5	3 1/2	3	4 1/2	2 3/4	1 7/32	1 17/32	15 1/4
2	3 7/8	3 3/8	5 1/4	3 1/4	1 11/32	1 21/32	17 1/8
3	4 1/8	3 5/8	6 3/8	3 3/4	1 17/32	1 57/64	20 1/4
5	3 1/2	3	7 3/8	3 3/4	1 27/32	2 13/64	23
10	4 1/4	3 5/8	11 1/8	4 7/8	2 43/64	2 61/64	31 1/8
15	4 1/4	3 5/8	13 3/8	8 1/8	3 3/16	3 35/64	39 7/8
20	6 1/8	6 1/8	15 3/8	15 3/8	3 3/16	3 35/64	40 5/8