

RATCHET PULLER MINI SERIES XT



2 YEARS WARRANTY

Compliant with ASME B30.21

Now available up to 3T!

TECHNICAL SHEET

1/4T to 3T

Compact, lightweight and robust

Grade 100 zinc plated chain

Tested at 150% capacity

Structural parts in alloy steel

Rugged aluminum housing

Weston-type brake with double pawls



With its 1.5 kg, its the world's smalessst lever hoist...
and most importantly, the sturdiest in its categort (XPU0.25T)

Easy to handle

- Top and bottom hooks rotate 360 degrees
- Ultra-short 360-degree handle rotation

Safe

- Ultra-robust fork-type forged safety latch

Weatherproof

- Zinc-plates grade 100 chain
- Aluminium housing

6-gear and 2-catch **gear reduction system** for superior performance.

4 links loas sprocket for better perfomance and stability.

Main parts and **gears** are made of **heat-treated alloy steel** and **cover** made of **aluminium alloy steel**.

Moving parts coated with **high-performance** Li-MoS2 (molybdenum disulfite) **grease** for optimal use in high & low temperature envinoments

Model	Capacity	Test Load (lb)	Standard chain length	Nb. of chain fall	∅ Load chain	Force to lift	Net weight*	Extra weight/ft
	Ton [lb]	lb			mm	lb	lb	lb
XPU0.25T	0.25 [551]	827	5	1	3.2	65	3.2	0.15
XPU0.5T	0.5 [1102]	1653			4.3	60	5.5	0.25
XPU0.75T	0.75 [1653]	2480			5	74	7.5	0.36
XPU01.5T	1.5 [3306]	4959			7.1	94	13.8	0.74
XPU03T	3 [6613]	9919		2	7.1	96	20	1.48

Model	Dimensions, mm (in)							
	A	B	C	D	Hmin	K	L	T
XPU0.25T	87 [3.43]	55.5 [2.16]	68 [2.68]	32 [1.26]	200 [7.87]	21 [0.83]	145 [5.71]	11 [0.43]
XPU0.5T	100.5 [3.96]	62.5 [2.46]	81 [3.19]	34.5 [1.36]	250 [9.84]	24.5 [0.96]	160 [6.30]	12 [0.47]
XPU0.75T	105 [4.13]	64 [2.52]	92 [3.62]	35.5 [1.40]	260 [10.24]	28.5 [1.12]	180 [7.09]	14 [0.55]
XPU01.5T	122 [4.80]	68.5 [2.70]	109 [4.29]	42.5 [1.67]	330 [12.99]	35 [1.38]	220 [8.66]	21.5 [0.85]
XPU03T	122 [4.80]	68.5 [2.70]	160 [6.30]	50 [1.97]	432 [17.01]	43 [1.69]	220 [8.66]	24.5 [0.96]

* For a ratchet puller with 5' standard

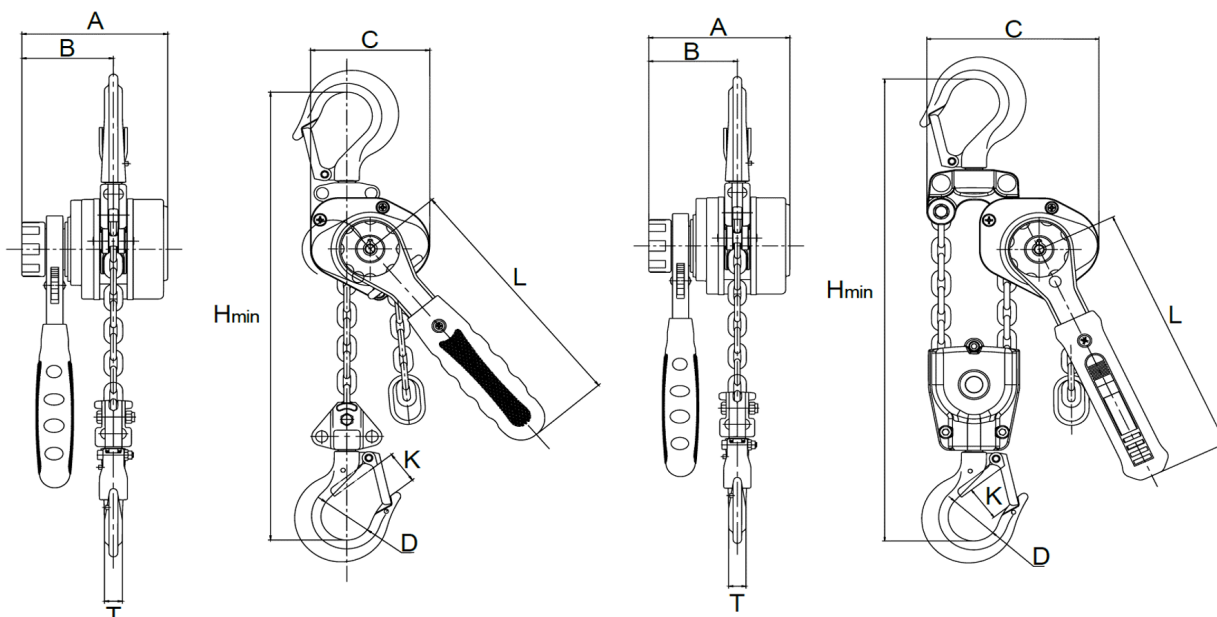

** Only for XPU0.25T, XPU0.5T and XPU0.75T.