

Hack10 Clevis Grab Hook

The Hack10 clevis grab hook is fundamentally used to grab chain. As a result, it is commonly used in lifting applications as a chain shortening device, as well as for lashing. This grab hook is capable of attachment directly onto chain thanks to its clevis attachment type. Manufactured from alloy steel, the Hack10 clevis grab hook is 25% stronger than a grade 8 equivalent, delivering a greater working load limit without the need for a larger diameter chain sling.

Standards: designed and manufactured in accordance with EN1677-1, ASTM A952/A952M, and DIN PAS 1061 and suitable for use in chain slings certified to EN818-4.

Product sizes: available for chain sizes from 8mm to 16mm and with working load limits from 2.5 tonnes to 10.0 tonnes.

Temperature: operational temperature range of - 40°C to + 200°C without reduction in working load limit.

Material: alloy steel.

Testing: crack detection following heat treatment, and proof load tested to 2.5 times working load limit.

Safety factor: 4 : 1.

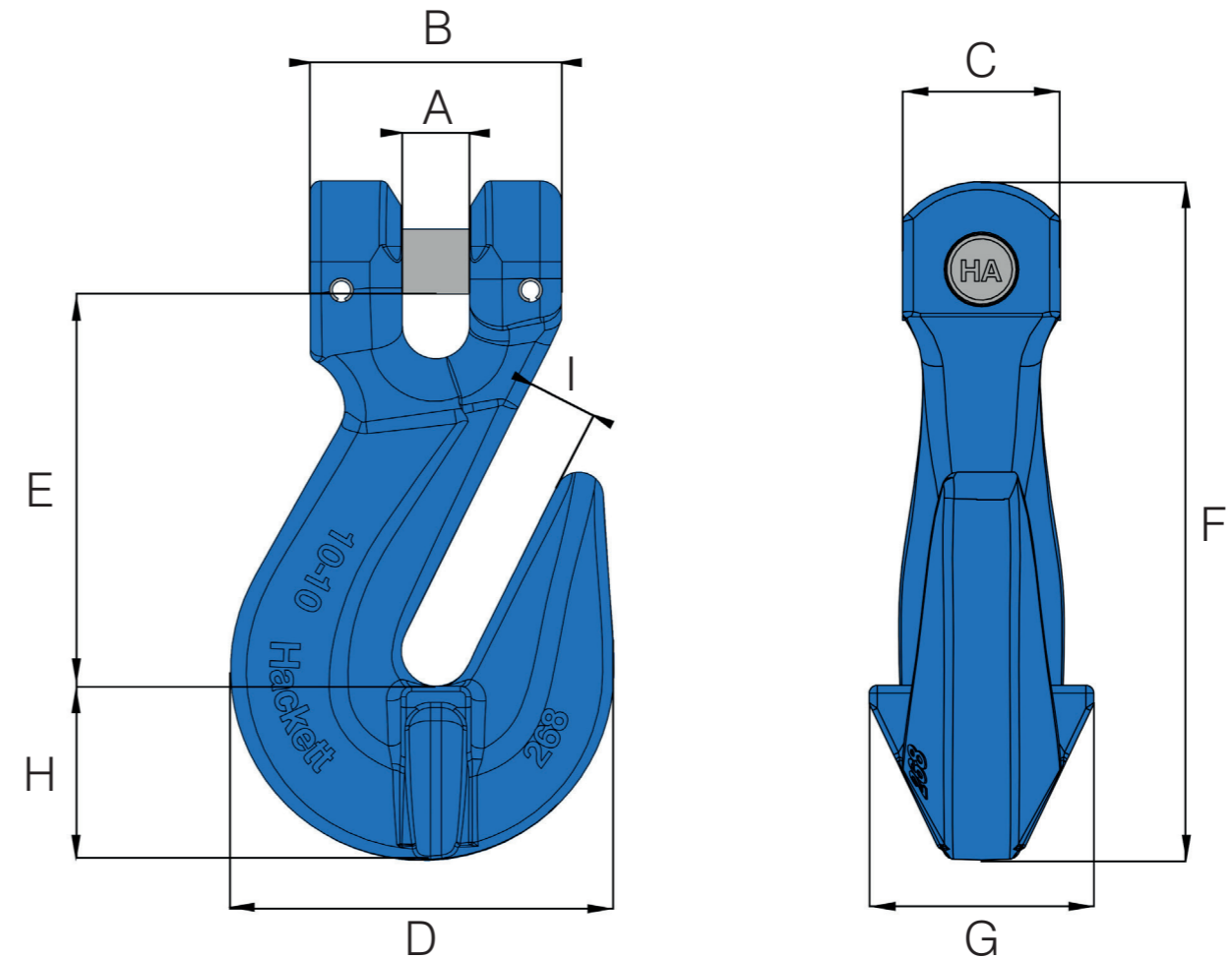

Metric Specifications

PART CODE	CHAIN SIZE mm	A mm	B mm	C mm	D mm	E mm	F mm	G mm	H mm	I mm	BOX QTY.	WLL tonnes	MASS kg
10-H19-08	8	9.5	36.0	24.0	54.0	53.0	93.0	33.5	22.0	11.0	70	2.5	0.34
10-H19-10	10	12.5	46.0	30.0	72.0	73.0	127.0	42.0	32.0	13.5	25	4.0	0.92
10-H19-13	13	15.0	59.0	37.0	96.0	92.0	164.0	53.5	45.0	15.0	15	6.7	1.98
10-H19-16	16	18.5	70.0	46.0	115.0	103.0	188.0	74.0	47.5	19.0	6	10.0	3.42

Hack10 Clevis Grab Hook

The Hack10 clevis grab hook is fundamentally used to grab chain. As a result, it is commonly used in lifting applications as a chain shortening device, as well as for lashing. This grab hook is capable of attachment directly onto chain thanks to its clevis attachment type. Manufactured from alloy steel, the Hack10 clevis grab hook is 25% stronger than a grade 8 equivalent, delivering a greater working load limit without the need for a larger diameter chain sling.

Standards: designed and manufactured in accordance with EN1677-1, ASTM A952/A952M, and DIN PAS 1061 and suitable for use in chain slings certified to EN818-4.

Product sizes: available for chain sizes from 5/16 inch to 5/8 inch and with working load limits from 5,700 lbs to 22,600 lbs.

Temperature: operational temperature range of - 40°C to + 200°C without reduction in working load limit.

Material: alloy steel.

Testing: crack detection following heat treatment, and proof load tested to 2.5 times working load limit.

Safety factor: 4 : 1.

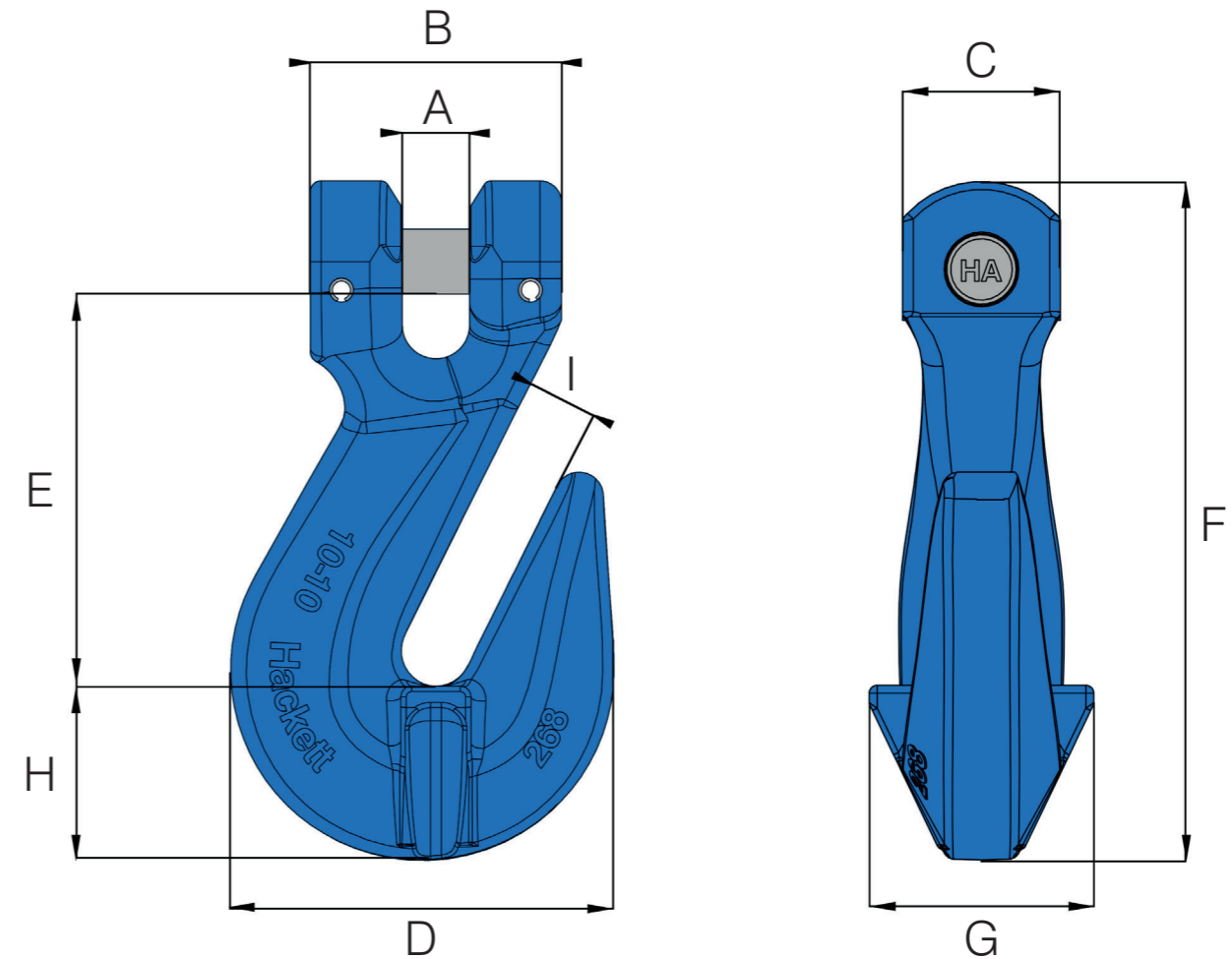

Imperial Specifications

PART CODE	CHAIN SIZE inch	A inch	B inch	C inch	D inch	E inch	F inch	G inch	H inch	I inch	BOX QTY.	WLL lbs	MASS lbs
10-H19-08	5/16	0.37	1.42	0.94	2.13	2.09	3.66	1.32	0.87	0.43	70	5700	0.75
10-H19-10	3/8	0.49	1.81	1.18	2.83	2.87	5.00	1.65	1.26	0.53	25	8800	2.03
10-H19-13	1/2	0.59	2.32	1.46	3.78	3.62	6.46	2.11	1.77	0.59	15	15000	4.37
10-H19-16	5/8	0.73	2.76	1.81	4.53	4.06	7.40	2.91	1.87	0.75	6	22600	7.54