

To: _____

Attn: _____ City: _____ Reference: _____

Tel.: _____ Fax: _____ From: _____

Vulcan

Superior Quality

2 YEARS GUARANTEE

APPROVED
ANSI B30.16

Triple Spur Gear Enclosed Chain Blocks

★ **EXCLUSIVE HAND WHEEL COVER**

The unique design effectively guides the hand chain into pockets of the chain wheel for easy vertical or angle pulling without jamming.

★ **HOOKS**

Upper & lower hooks are steel drop forgings, heat treated for strength and long wears, and swivel to all directions.

★ **HAND CHAIN** Polished.

HEAT TREATED ALLOY STEEL CHAIN

See break test on each capacity.

2 LOAD CHAIN GUIDES

1 as chain comes out of sprocket & 1 as chain enters sprocket, reduces friction-wear of chain & sprocket, most important on long lifts where chain could be twisted, as it guides each link into sprocket.

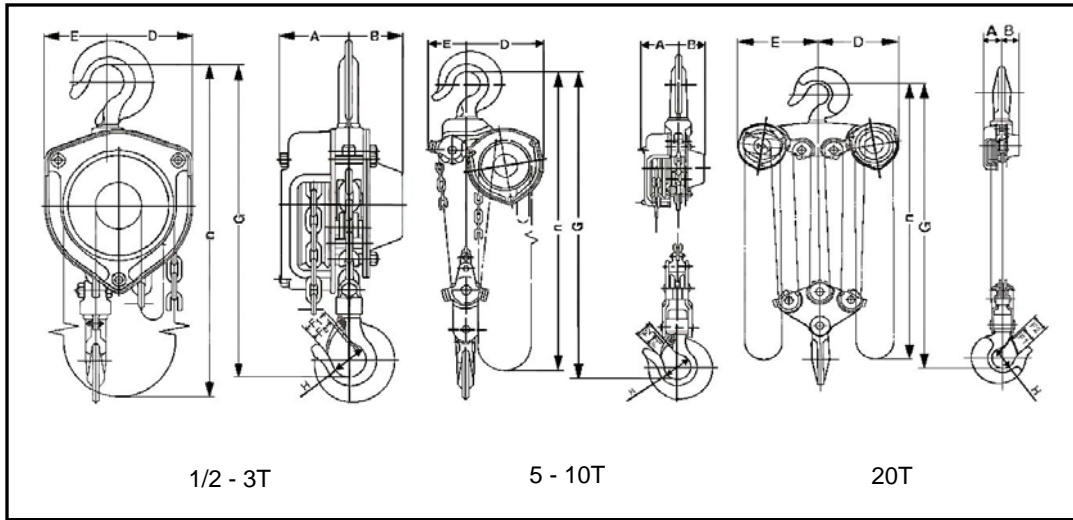

Overload
Protection
Available
1/2 - 5T incl.



Capacity tons	Safe working load lb	Test load tons	Standard lift		Pulling effort		No. of chain falls	G Headroom (hook to hook)		Net weight		Chain break test lb
			ft.	m	lb	kg		in	mm	lb	kg	
1/2	1,100	0.75	10	3	46	21	1	11 1/4	286	18	8	7,100
1	2,200	1.5			53	24	1	13 1/2	343	23	10.5	11,200
1.6	3,520	2.4			65	29.5	1	15 1/4	387	33	15	14,200
2	4,400	3			74	33.5	1	17 1/8	435	46	21	17,950
3.2	6,930	4.8			84	38	1	20 1/4	514	67	30.5	36,000
5	11,000	7.5			79	36	3	23	584	77	35	17950 x 3
10	22,000	12.5			95	43	3	31 1/8	1020	167	76	36000 x 3
20	44,000	25			99	45	6	40 5/8	1040	551	250	36000 x 6

Capacity tons	A		B		D		E		F1		F2	
	in.	mm	in.	mm	in.	mm	in.	mm	in.	mm	in.	mm
1/2	3 1/4	82	2 1/4	56	3 1/2	90	1 7/8	48	1	24	1 3/8	36
1	3 3/8	84	2 5/8	66	4	100	2 3/8	59	1 1/8	29	1 5/8	43
1.6	3 5/8	91	3	77	4 1/2	115	2 3/4	69	1 1/4	33	1 7/8	48
2	3 7/8	99	3 1/2	88	5 1/8	132	3 1/4	82	1 3/8	35	2	52
3.2	4 1/8	106	3 3/4	94	6 1/4	160	3 3/4	94	1 1/2	40	2 3/8	60
5	3 5/8	91	3	77	8	205	3 3/4	94	1 7/8	47	2 5/8	68
10	4 1/8	106	3 3/4	94	11 1/8	283	4 7/8	122	2 5/8	68	3 3/4	95
20	6	153	6	153	15 3/8	390	15 3/8	390	3 1/8	79	4 7/8	125

Up to 100 T. on request

Short headroom on request, from stock

Hand chain: 3ft less than lift

Specify approx headroom required

Upper & lower latches included.

Specifications subject to change without notice.

Discount: _____ Taxes/Transport extra

We do not assume responsibility for failure or delay in deliveries caused by strike, shortage in materials or due to any other circumstances beyond our control

Delivery: _____ days approx. Prices firm 30 days

VULCAN HOIST CO. LTD.

3435 CREMAZIE E MONTREAL QC H1Z 2J2 T. 514-728-4527 F. 514-374-4231

E-mail: info@vulcanhoist.com Web: www.vulcanhoist.com