

NOVA-E RATCHET PULLERS

VULCAN HOIST CO LTD

MONTREAL QC H1Z 2J2 T: 514-728-4527 F: 514-374-4231

E-MAIL : vulcan@contact.net WEB : www.vulcanhoist.com

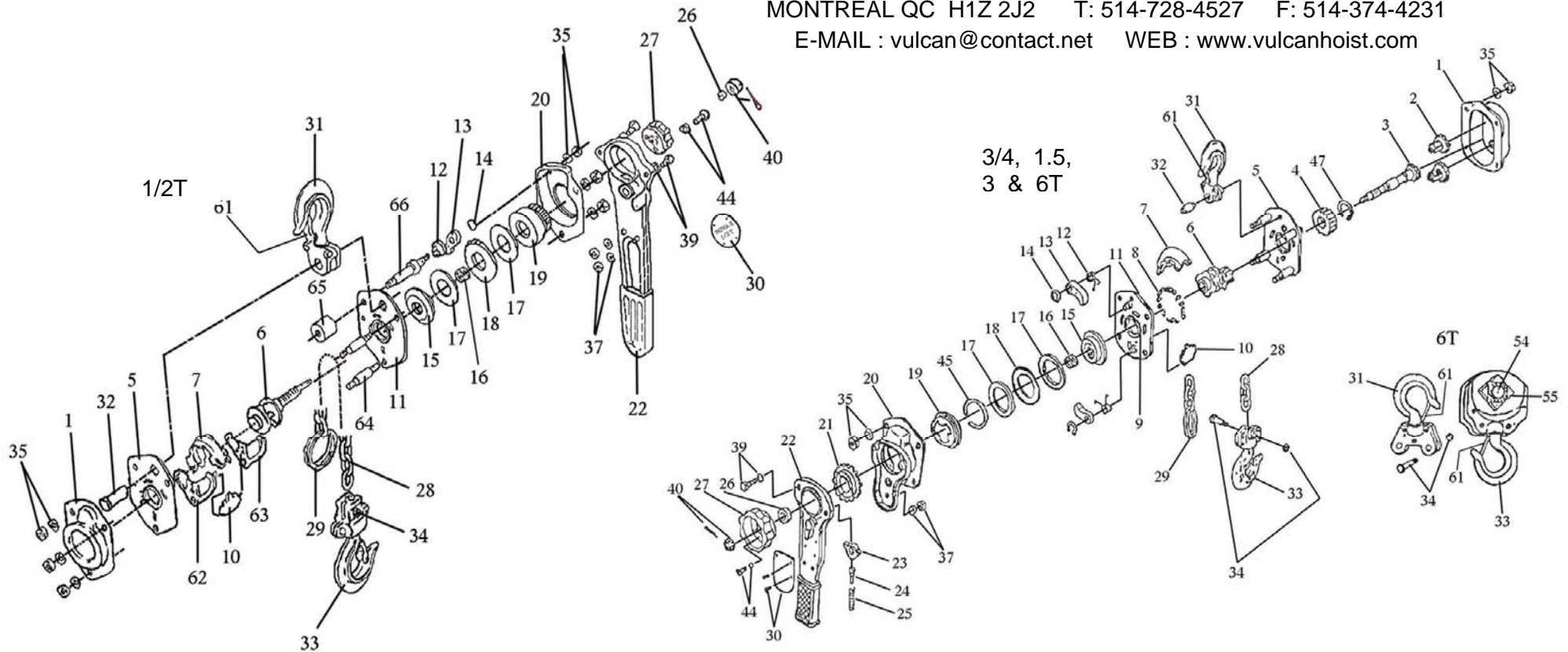

Part #	Description	Part #	Description	Part #	Description	Part #	Description
1	Gear cover	13	Pawl	26	Bushing	44	Screw & lock washer
2	Pinion w/pinion gear	14	Snap ring for pawl	27	Guide handle	45	Brake snap ring
3	Pinion shaft	15	Disc hub	28	Load chain	47	Load gear snap ring
4	Load gear	16	Free wheel spring	29	Stop grip	54	Sprocket pin for bottom hook
5	Gear side plate	17	Friction disc	30	Name plate w/screws	55	Sprocket for bottom hook
6	Load sheave	18	Ratchet wheel	31	Top hook w/yoke & latch	61	Safety latch
7	Chain guide	19	Female disc nut	32	Yoke pin for top hook	62	Left chain plate
8	Roller bearings complete	20	Ratchet cover	33	Bottom hook w/yoke, latch & #34	63	Right chain plate
8A	Rollers only	21	Disc nut	34	Load chain fastening bolt & nut	64	Stay bolts
9	Bearing race (incl w/#5 or 11 Only)	22	Operating handle (Complete 1/2T Only)	35	Hex nut w/lock washer	65	Spacer bushings
10	Stripper	23	Change over pawl	37	Hex nut & locke washer	66	Pawl shaft
11	Handle side plate assy	24	Spring shaft	39	Screw & lock washer		
12	Pawl spring	25	Change over spring	40	Check nut & cotter pin		